



Operating Manual



Loctite[®] 250ml Peristaltic Hand Pump
97001

Loctite[®] 50ml Peristaltic Hand Pump
98414

Description

The LOCTITE® 250ml Bottle Hand Pump 97001 is a portable, precision, bottle-top applicator that threads firmly onto any 250ml anaerobic bottle. It converts the product bottle into a manual mobil dispenser. The LOCTITE® 50ml Bottle Hand Pump works by the same principle and threads firmly onto any 50ml anaerobic bottle. It includes a new ergonomically balanced and resilient bottle stand that greatly reduces the tendency of bottle tipping. These units will dispense single shots of Loctite® anaerobic Threadlockers and Retaining Compounds from 0.01 to 0.4 ml with viscosities up to 30,000 mPas. They require no flushing, power or air source. They are designed to dispense at any angle without leaks and eliminate waste of product.

This device is not suitable for Cyanoacrylates, Primers and Activators.

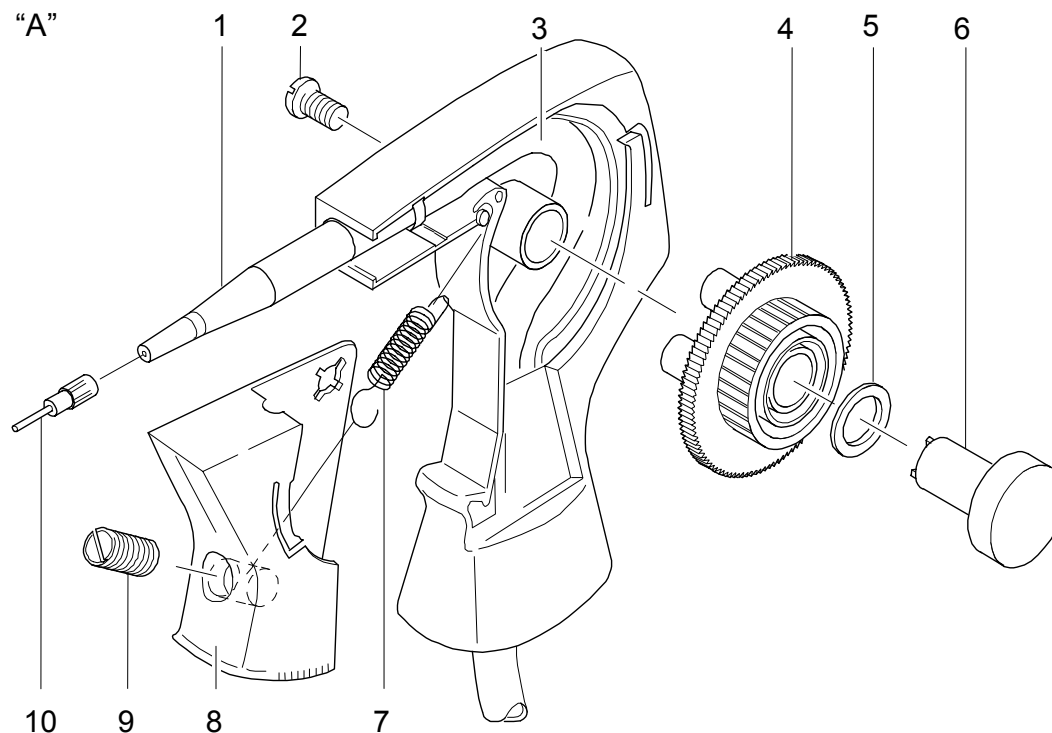

- | | |
|--|---------------------|
| 1. Nozzle 993174 | 6. Cover Cap |
| 2. Screw | 7. Spring |
| 3. 250ml Tube 993163
50ml Tube 988225 | 8. Trigger |
| 4. Dispense Wheel | 9. Adjusting Screw |
| 5. Rubber Washer | 10. Dispense Needle |

Notice: Parts with type number are available as spare parts.

Function

The hand pump is screwed onto the Original-Loctite® Product Bottle. By pressing the Trigger **8** the Dispense Wheel **4** is turned, and a precise product amount is feeded through the Tube **3** to the Nozzle **1**.

The dispensed amount depends on the stroke of the Trigger **8**. The stroke is adjusted via the Adjusting Screw **9**.

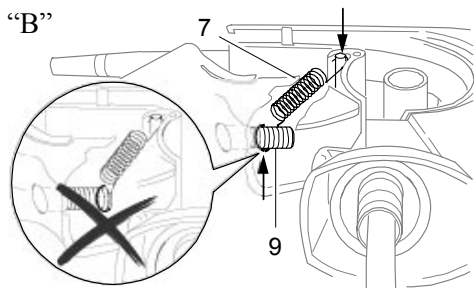

- Assemble Spring 7 correctly, to prevent its jumping out, when the Adjusting Screw 9 is turned

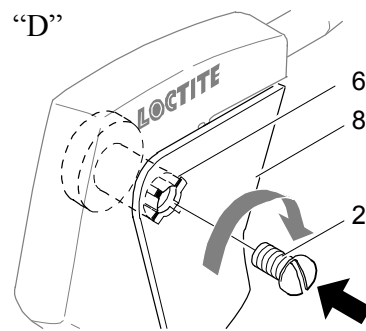

- Insert Cover Cap 6 with the wedges of the shaft into the Trigger 8
- Assemble Screw 2 and tighten it

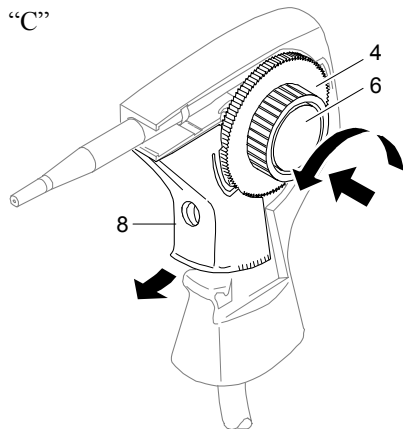

- Assemble Cover Cap 6 with Washer 5 and Dispense Wheel 4
- Turn Dispense Wheel 4 CCW and while slightly pressing on, until the catch snaps to cogs
- Pull Trigger 8 forward, in order that the catch can snap into the Dispense Wheel 4

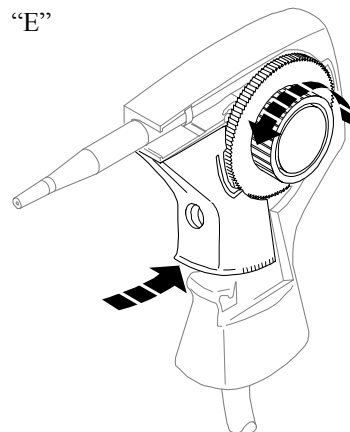

- Test function

“F”



- **250-ml-Loctite® Product Bottle:**
- Put a rubber disc onto the bottle neck
- Screw the Hand Pump onto the product bottle

“G”



- **50-ml-Loctite® Product Bottle:**
- Stick the bottle neck through the hole of the stand
- Put a rubber disc onto the bottle neck (see next page)

“I”

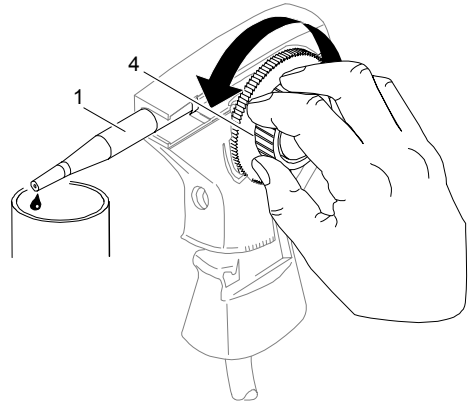

- **Priming the Pump:** Turn Dispense Wheel **4** CCW, until the product comes out of the Nozzle **1**

“H”

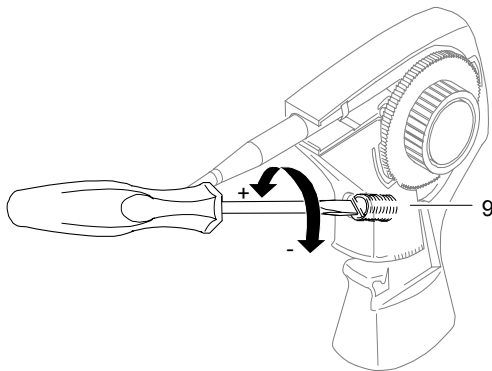

The dispense amount depends on the stroke adjustment of the Trigger **8**.

- Press and release the Trigger **8**
- Adjust the dispense amount via the Adjusting Screw **9**:
 - To increase the dispense amount unscrew the Adjusting Screw **9**.
 - To decrease the dispense amount screw in the Adjusting Screw **9**.

Correct malfunctions

Type of failure	Possible reason	Corrective
No product	Clogged Nozzle 1 .	Clean Nozzle 1 .
No counterforce of the Trigger 8 .	Spring 7 not on the Adjusting screw 9 .	Insert Spring 7 correctly.
Dispense Wheel 4 is not moving.	Wrong assembled Dispense Wheel 4 .	Assemble Dispense Wheel 4 correctly.

98414 consists of three parts plus the product bottle.

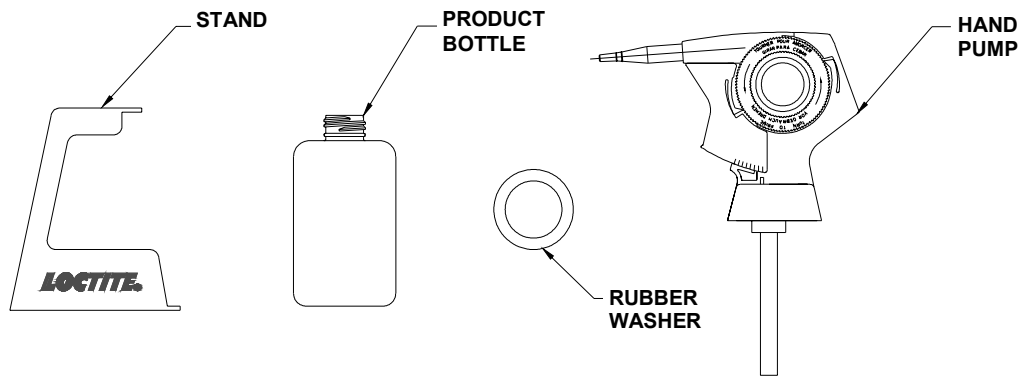

Assembly

1. Push the product bottle into the stand and stick the bottle neck through the hole of the stand.
2. Put the rubber washer onto the bottle neck.

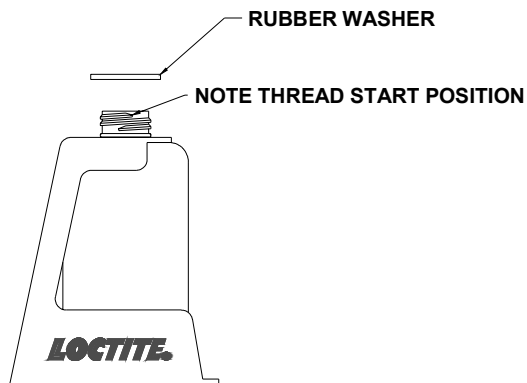

3. Insert pump tube into the product bottle.
Screw the hand pump onto the threaded bottle neck.

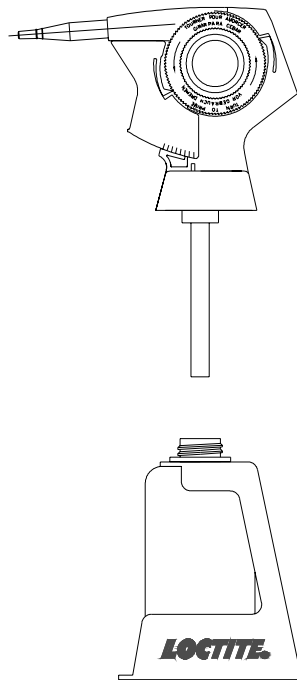

4. Screw hand pump onto the bottle until it fits tight to the bottle (ca. 1.5 Nm).
At the right positioning of the thread start, the hand pump is orientated as shown below. If the hand pump shows vice versa, unscrew the hand pump, turn the bottle 180° and screw the hand pump on again.

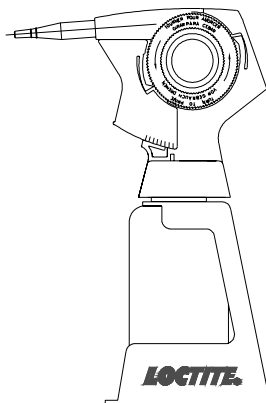

WARRANTY

Henkel expressly warrants that all products referred to in this Instruction Manual for (97001 & 98414 Bottle Hand Pumps) (hereafter called "Products") shall be free from defects in materials and workmanship. Liability for Henkel shall be limited, as its option, to replacing those Products which are shown to be defective in either materials or workmanship or to credit the purchaser the amount of the purchase price thereof (plus freight and insurance charges paid therefor by the user). The purchaser's sole and exclusive remedy for breach of warranty shall be such replacement or credit.

A claim of defect in materials or workmanship in any Products shall be allowed only when it is submitted in writing within one month after discovery of the defect or after the time the defect should reasonably have been discovered and in any event, within (12) months after the delivery of the Products to the purchaser. This warranty does not apply to perishable items. No such claim shall be allowed in respect of products which have been neglected or improperly stored, transported, handled, installed, connected, operated, used or maintained. In the event of unauthorized modification of the Products including, where products, parts or attachments for use in connection with the Products are available from Henkel, the use of products, parts or attachments which are not manufactured by Henkel, no claim shall be allowed.

No Products shall be returned to Henkel for any reason without prior written approval from Henkel. Products shall be returned freight prepaid, in accordance with instructions from Henkel.

NO WARRANTY IS EXTENDED TO ANY EQUIPMENT WHICH HAS BEEN ALTERED, MISUSED, NEGLECTED, OR DAMAGED BY ACCIDENT, OR IF THE SYSTEM WAS USED TO DISPENSE ANY LIQUID MATERIAL OTHER THAN LOCTITE® PRODUCTS.

EXCEPT FOR THE EXPRESS WARRANTY CONTAINED IN THIS SECTION, HENKEL MAKES NO WARRANTY OF ANY KIND WHATSOEVER, EXPRESS OR IMPLIED, WITH RESPECT TO THE PRODUCTS.

ALL WARRANTIES OF MERCHANTABILITY, FITNESS FOR A PARTICULAR PURPOSE, AND OTHER WARRANTIES OF WHATEVER KIND (INCLUDING AGAINST PATENT OR TRADEMARK INFRINGEMENT) ARE HEREBY DISCLAIMED BY HENKEL AND WAIVED BY THE PURCHASER.

THIS SECTION SETS FORTH EXCLUSIVELY ALL OF LIABILITY FOR HENKEL TO THE PURCHASER IN CONTRACT, IN TORT OR OTHERWISE IN THE EVENT OF DEFECTIVE PRODUCTS.

WITHOUT LIMITATION OF THE FOREGOING, TO THE FULLEST EXTENT POSSIBLE UNDER APPLICABLE LAWS, HENKEL EXPRESSLY DISCLAIMS ANY LIABILITY WHATSOEVER FOR ANY DAMAGES INCURRED DIRECTLY OR INDIRECTLY IN CONNECTION WITH THE SALE OR USE OF, OR OTHERWISE IN CONNECTION WITH, THE PRODUCTS, INCLUDING, WITHOUT LIMITATION, LOSS OF PROFITS AND SPECIAL, INDIRECT OR CONSEQUENTIAL DAMAGES, WHETHER CAUSED BY NEGLIGENCE FROM HENKEL OR OTHERWISE.

Henkel Corporation
1001 Trout Brook Crossing
Rocky Hill, CT 06067-3910

Henkel Canada Corporation
2225 Meadowpine Boulevard
Mississauga, Ontario L5N 7P2

Henkel Capital, S.A. de C.V.
Calzada de la Viga s/n Fracc. Los
Laureles
Loc. Tulpetlac, C.P. 55090
Ecatepec de Morelos, Edo. de México

**Henkel Automotive
Technology Center**
2455 Featherstone Road
Auburn Hills, Michigan 48326

Henkel Ltda.
Rua Karl Huller, 136 – Jd.
Canhema 09941-410
Diadema/SP, Brazil

www.loctite.com

Loctite ist ein Warenzeichen der Firma Henkel. © Copyright 2004. Henkel Corporation
Alle Rechte vorbehalten. Technische Änderungen vorbehalten.
Manual P/N: xxxxxx Rev B, Date: 06/2007

